

## **Case Studies: Desktop Virtualization**

**Dave Cohen, Director, Merrill Lynch**

**September 24, 2007**

# Who We Are

Merrill Lynch is a leader in wealth management, capital markets and advisory services

- **Founded:** 1914 (Charles E. Merrill & Co)
- **Employees:** 61,900
- **Q2 2007 Net Revenue:** \$9.7 billion
- **Total Client Assets:** Approx. \$1.7 trillion
- **Total Stockholders' Equity:** \$41 billion
- **Fortune 500:** Ranked No.22
- **Stock Symbol:** MER
- **Global Markets:** 38 countries

# What is Desktop Virtualization?

Software that presents an end-user desktop as a service.

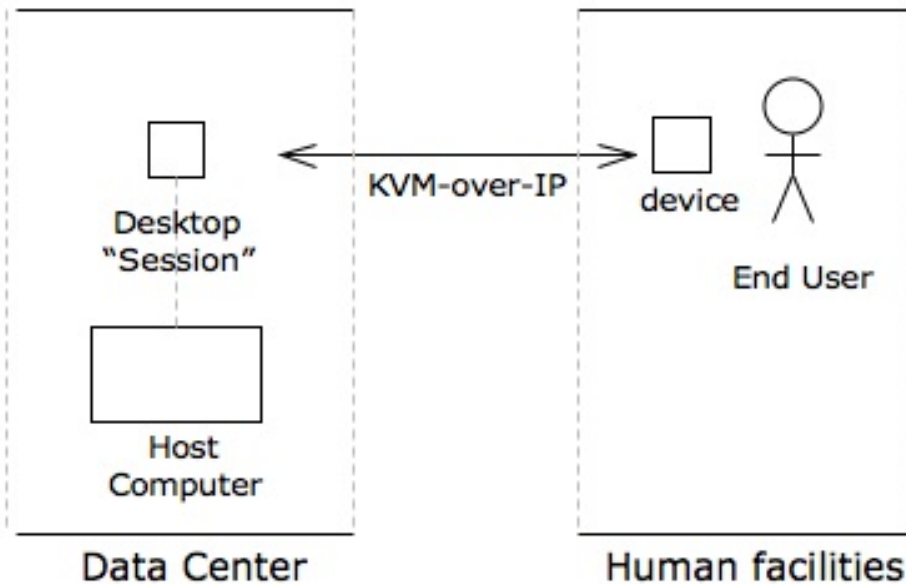

- For the End User, access is via a thinned down device whose primary functions are Keyboard, Video, and Mouse (KVM)
- Physically, this device is connected to the Ethernet, has an IP address, and runs a minimal amount of software; including the client side of a terminal server protocol such as RDP ("Remote Desktop Protocol")
- The End User's actual "Desktop" resides in the "Cloud" where it is accessible via RDP, i.e. it is running the server side of the terminal server protocol.

# Why we need Desktop Virtualization

- Minimize the impact/costs of "*Moves/Adds/Change (MAC)s*"
- Reduce complexity by centralizing Operating System and Application "*software distribution, patching, support, and upgrades.*"
- Increase "*data protection*" through centralization of its storage and long term management
- Other Motivations
  - Mergers and Acquisition (M&A)
  - Reduce Power & Cooling costs in branch offices
  - Improve mobility (e.g. "Free Seating," "Home Office," etc)
  - Increase enforcement of Compliance/Regulatory constraints. For example, enforcement of the Firm's Software Licensing Policies that prohibit unauthorized installation of software into Firm-owned assets.

# Implementations

- (1) **Terminal Services** - X-Windows, VNC, Citrix Metaframe, MSFT Terminal, LTSP, Win4Lin
- (2) **PC Server Blades** - ClearCube, HP's CCI
- (3) **Hybrid** - HP's Remote Graphics software, Calista Technologies, Teradici, Sun/Tarantella, Server Engines
- (4) **Desktop-on-a-Stick** - Moka5, OpenISR, MojoPAC
- (5) **Virtualized Desktop** - VMWare/VDI, Citrix/XenSource, Novia, Desktone, Qumranet, Provision Networks

# Data Management

- |   |  |
|---|--|
| (1) <b>Wide Area File System (WAFS) -</b>   | Cisco/Actona, Riverbed, Juniper/Perabit, Citrix/(Netscaler and Orbital Data) |
| (2) <b>File System Namespace -</b>          | Cisco/Neopath, EMC/Rainfinity, F5/Acopia Networks                            |
| (3) <b>File System Policy Enforcement -</b> | Cisco/Neopath, EMC/Rainfinity, F5/Acopia Networks                            |
| (4) <b>Clustering -</b>                     | CFS/Lustre, HP/Polyserv, IBM/GPFS, Redhat/GFS ("Sistina")                    |
| (5) <b>De-Duplication -</b>                 | Data Domain, Riverbed  |

# System Management

- (1) **Image Management -** Stanford/Collective project; Carnegie Mellon/OpenISR project; University of Arizona/Stork; CohesiveFT
- (2) **Configuration Management -** Opsware; BladeLogic; Planetlab's Application Manager; XenoServer; Boston University's PACMAN (Globus)
- (3) **Application Virtualization -** Altiris/SVS, Citrix/Tarpon, MSFT/SoftGrid; ThinStall, Trigence, XenoCode
- (4) **License Management -** HP/Opware; BladeLogic; MSFT/SoftGrid;
- (5) **Provisioning -** HP/Opware; BladeLogic;
- (6) **Scheduling -** EverGrid; Cluster Resources; Platform/Symphony
- (7) **Load Balancing -** EverGrid; HP; VMWare/Vmotion; VirtualIron
- (8) **Monitoring -** Ganglia; PSER ("Planetary Scale Event Propagation and Routing")

# Scaling to Cover the Globe

*"A single multi-access computer would fill the bill if expense were no object, but there is no way, with a single computer and individual communication lines to several geographically separated consoles, to avoid paying an unwarrantedly large bill for transmission."*

--- Licklider et al, "The Computer as a Communication Device," 1968

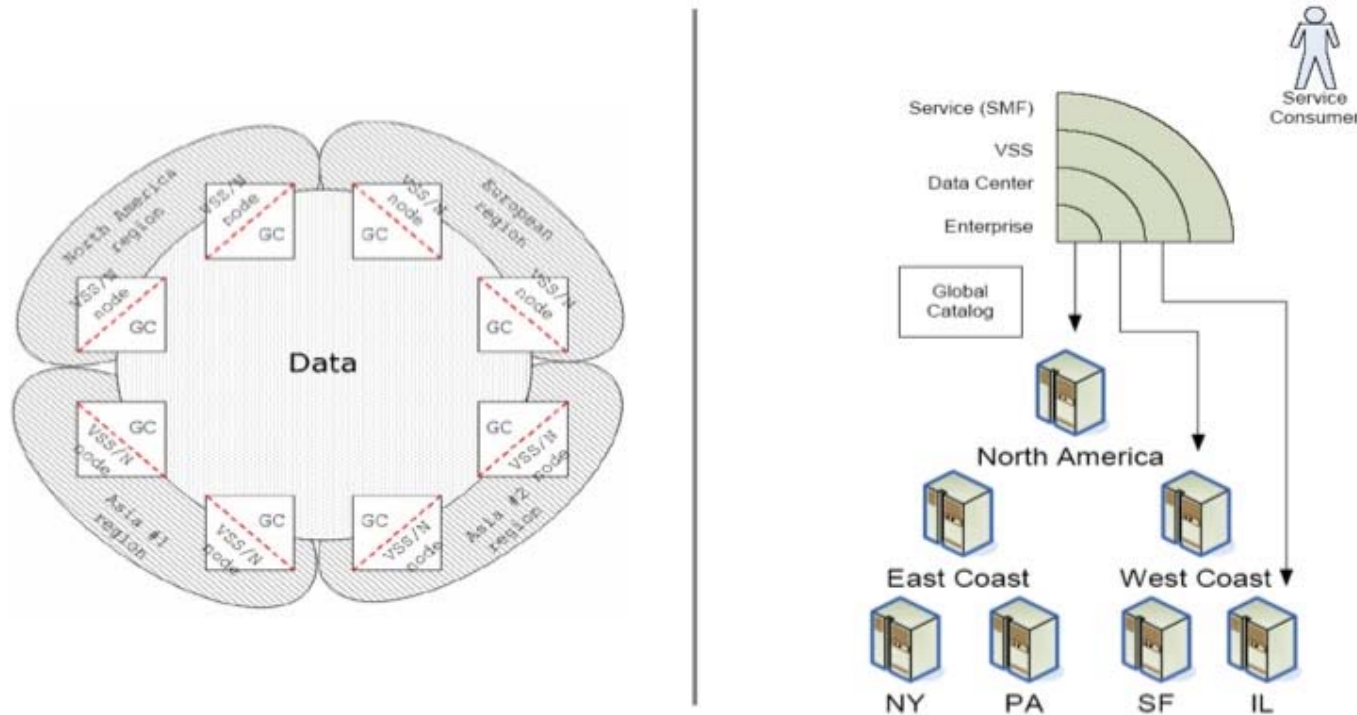

# Facilities: Ping/Power/Plumbing

- (1) Real Estate
  - Available Floor Space
  - Proximity to End-Users
  - Proximity to Backend Data Sources
  - Northern vs. Southern Hemisphere
- (2) Network Connectivity
  - Bandwidth and Latency between End-User and Desktop
  - Bandwidth and Latency between Desktop and Backend Data Sources
- (3) Power/Energy
  - ***Increase of between 10kW to 20kW per 1k users***
- (4) Cooling
  - Power-On/Power-Off
  - Digital Voltage Frequency Scaling (DVFS)
  - Throttling
  - “Live” Migration

# Virtual Hard Drive

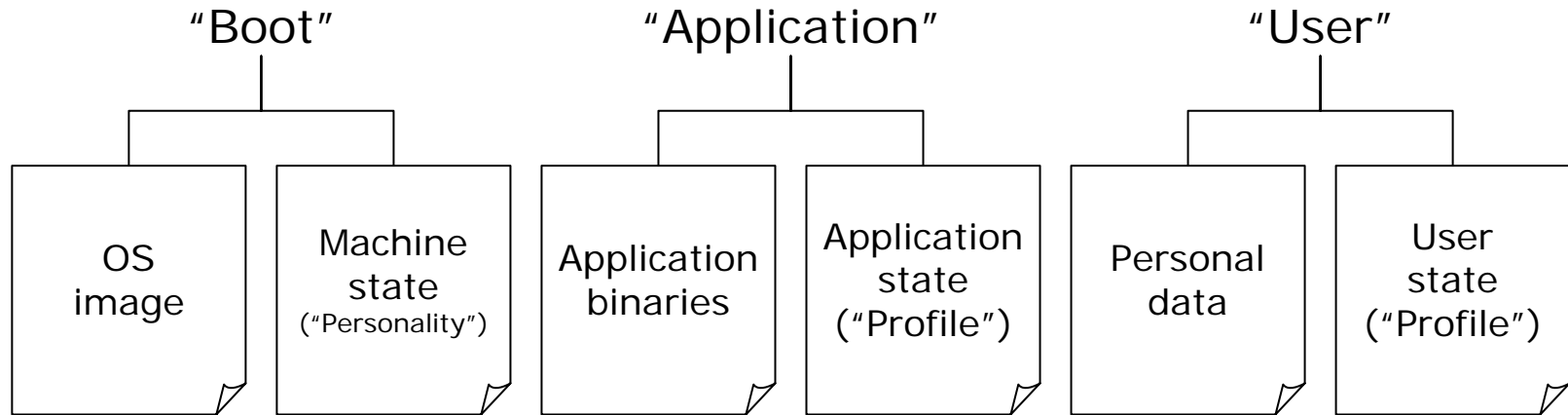

- "Gold" Copy/Template
  - Single instance
- App Virtualization
  - Streaming
  - Packaging
- Offline files
- Roaming Profiles

An increase in storage requirements of between 10 GB and 20 GB per desktop;

**!!! 10 TB to 20 TB per 1k desktops !!!**

# Rapid Repurposing via Automation

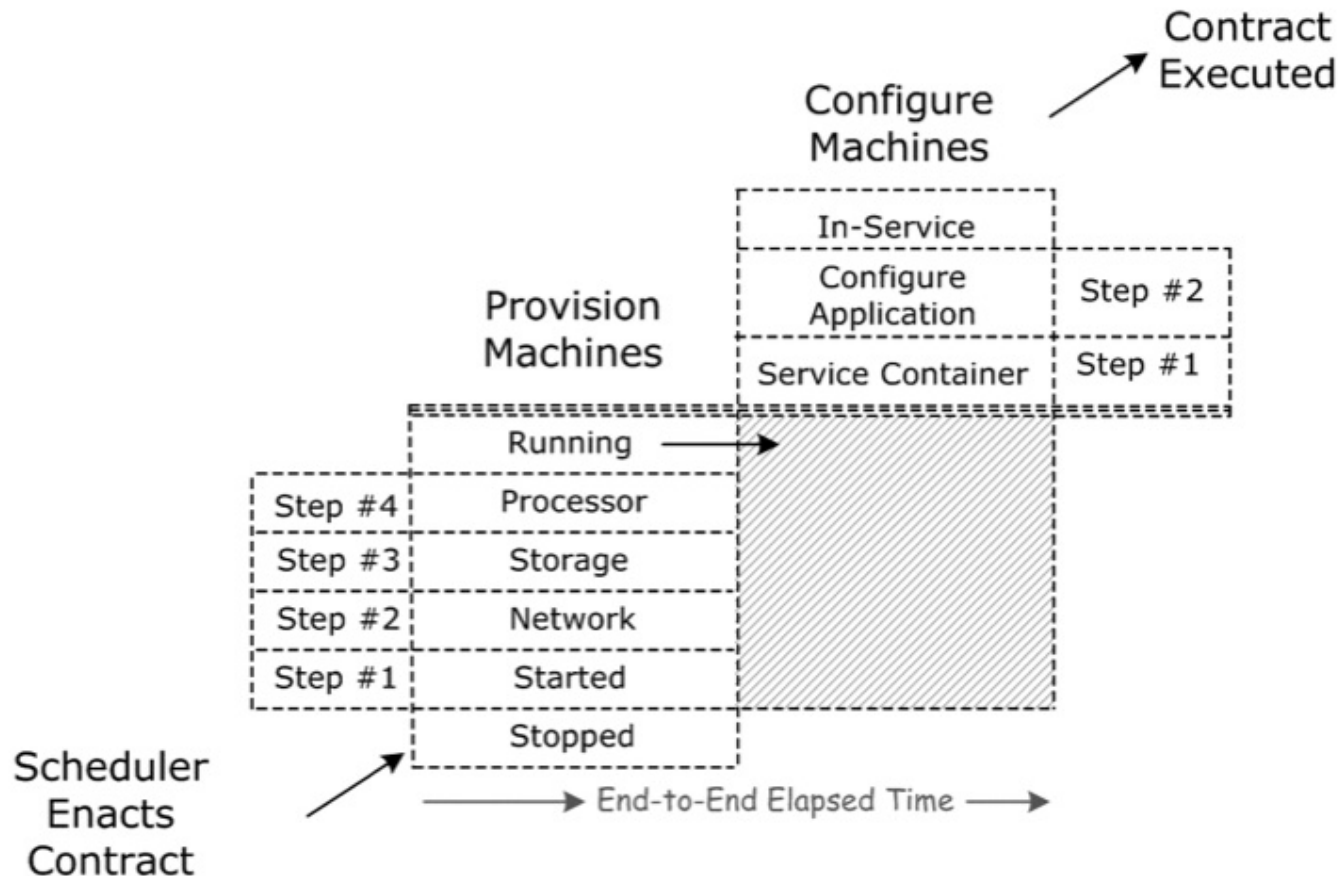

# The Virtual Workstation

- **Aug 2003** - Prototype using GSX, Chron, Perl, and rdesktop
- **Sept 2003 thru Mar 2004** - Worked on prototype that used Synchron's technology
  - Cohen, "Bladed Desktops: The Virtualization of Desktop Computers," UtilWorld's OnDemand Strategies for Business, March 2004  
<http://www.utilitycomputing.com/events/Pages/NewYork/agenda.asp>
- **Jan 2004 thru March 2004** - Worked in parallel with VMWare and Microsoft to evaluate suitability of their ESX and Virtual Server products respectively
  - Berc, "Desktop Hosting with VMware VirtualCenter and ESX Server," 2004
  - Koc, "Virtual Server POC," 2004
- **March 2004 thru Jun 2004** - Worked in parallel with HP and IBM to develop solution
  - Fore et al, "BladeCenter solutions," 2005  
<http://researchweb.watson.ibm.com/journal/rd/496/fore.htm>
  - Sahai et al, "Quartermaster - A Resource Utility System," 2004  
<http://www.hpl.hp.com/techreports/2004/HPL-2004-152.pdf>
- **July 2004 thru Jun 2005** - Worked in parallel with BMC, CA, HP, and IBM
  - Nokes et al, "Application of supply chain mechanisms to an on demand operating environment." Int. CMG Conference 2006: 143-154
- **Nov 2003 thru March 2006** - Worked with Softricity (now part of Microsoft)
  - Schaefer et al, "Modeling Data Centers as Economic Markets for Dynamic Service Provisioning and Resource Management," 2006  
<http://csdl2.computer.org/persagen/DLAbstoc.jsp?resourcePath=/dl/proceedings/vtdc/&toc=comp/proceedings/vtdc/2006/2873/00/2873toc.xml&DOI=10.1109/VTDC.2006.7>

# Desktop Virtualization "Stack"

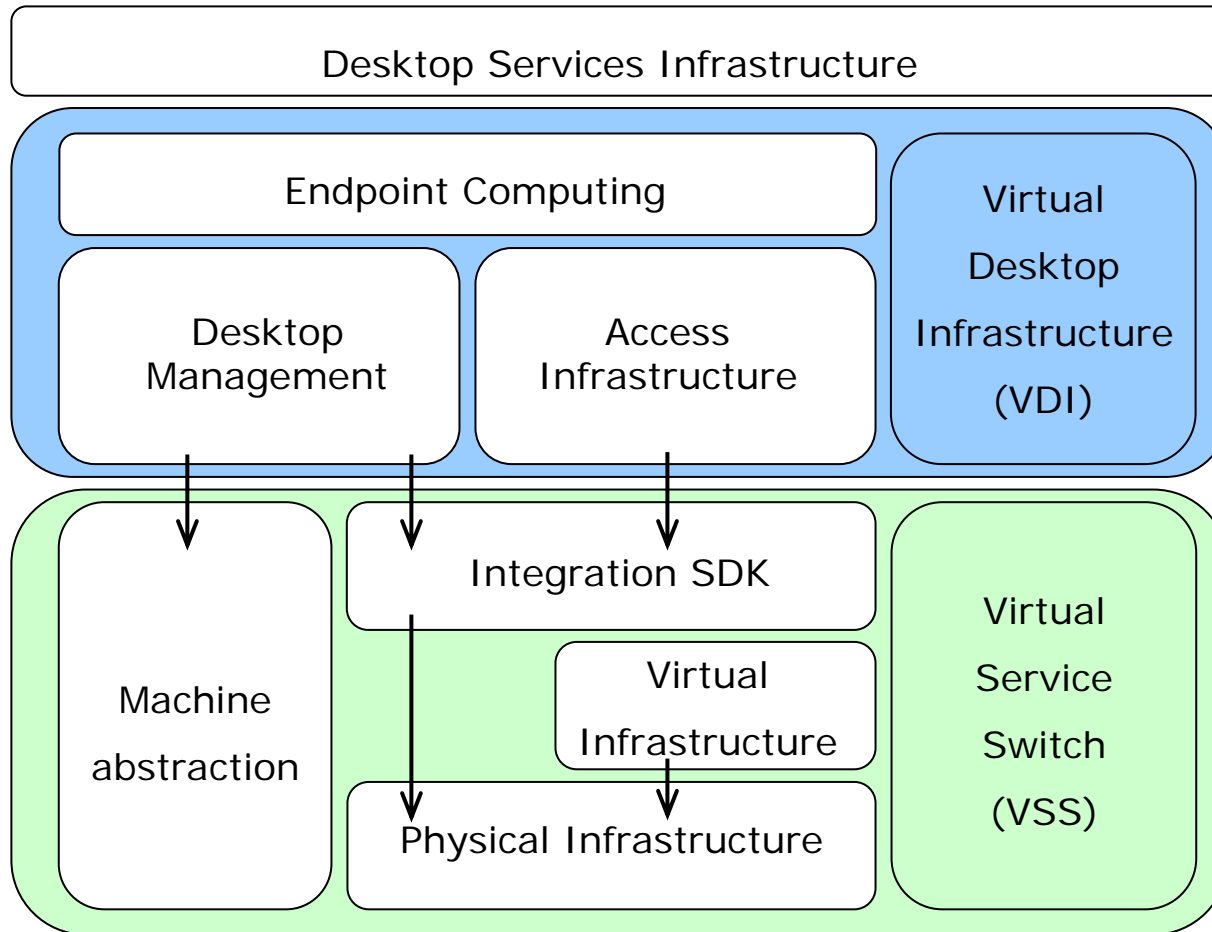

# VSS Logical Architecture

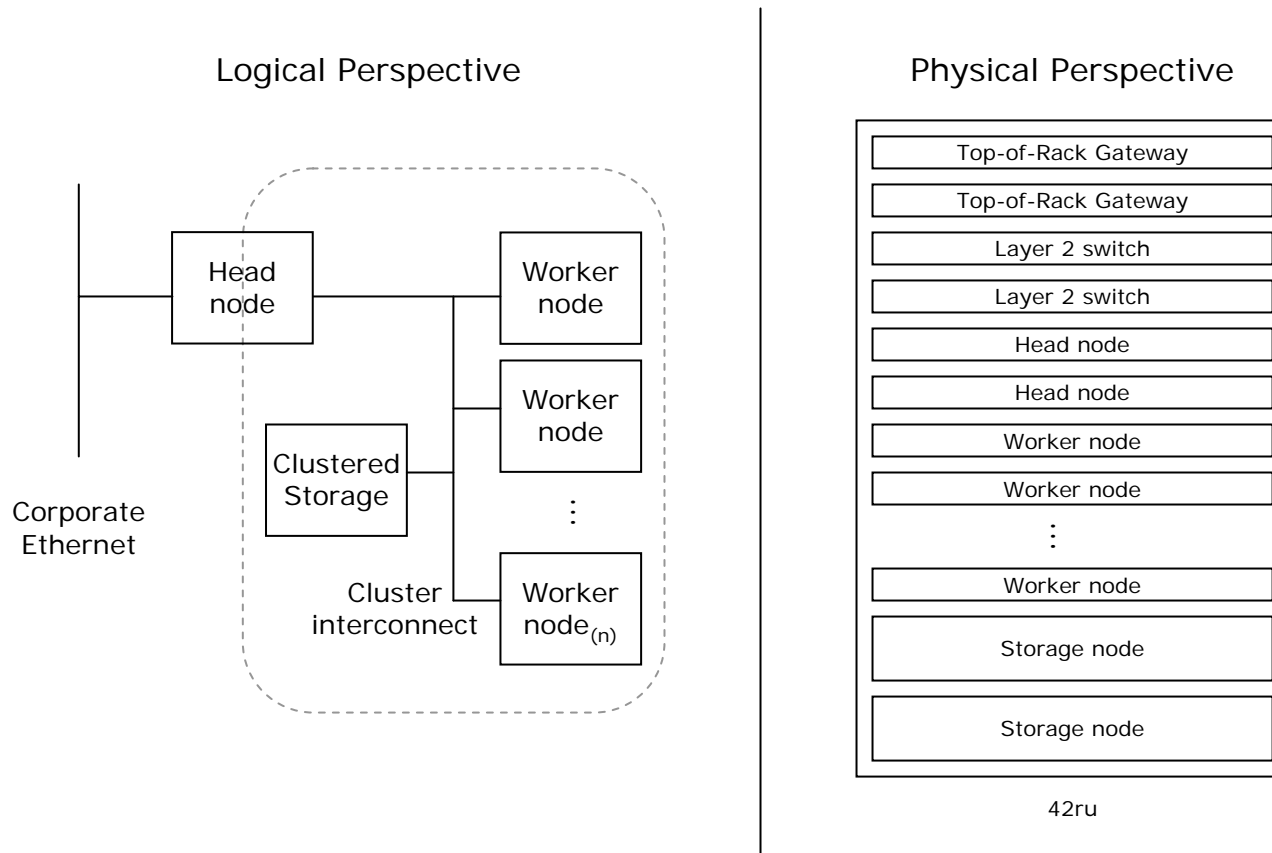

# VSS Software Architecture

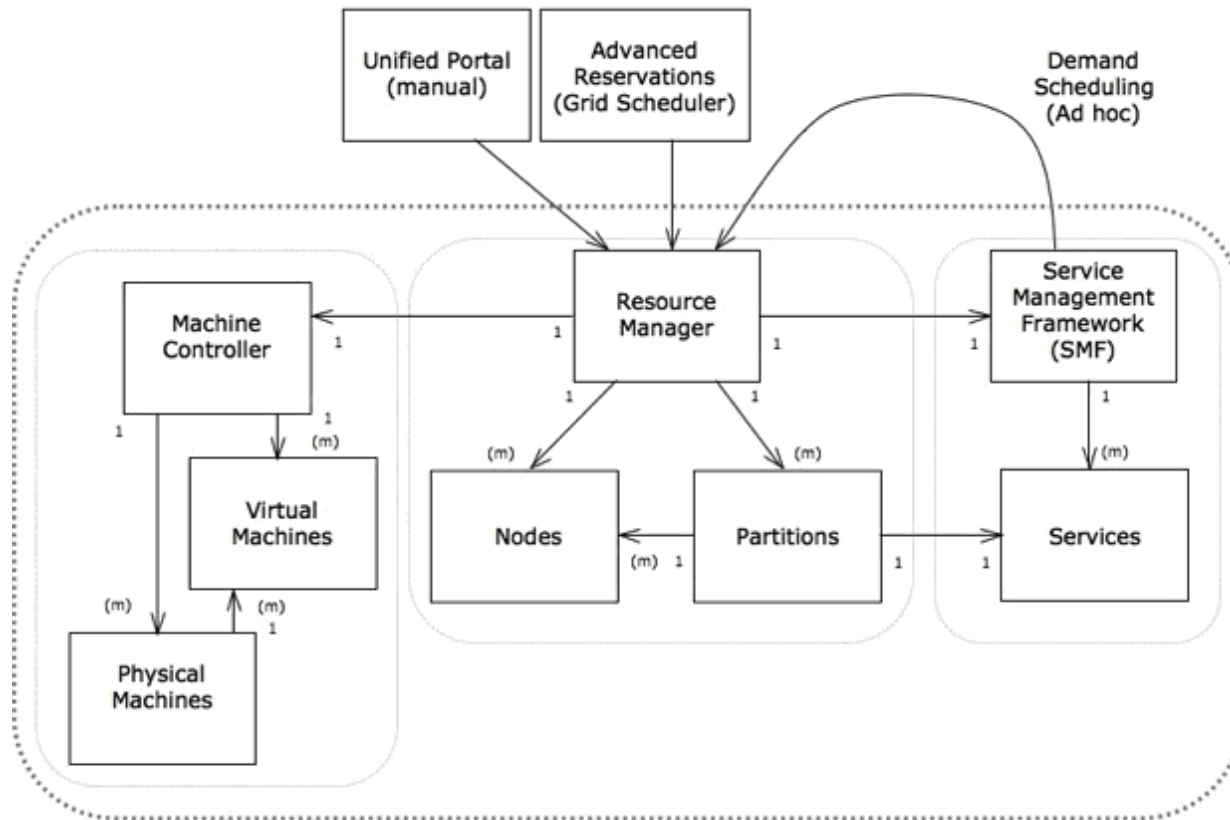

# VSS Service Management Framework

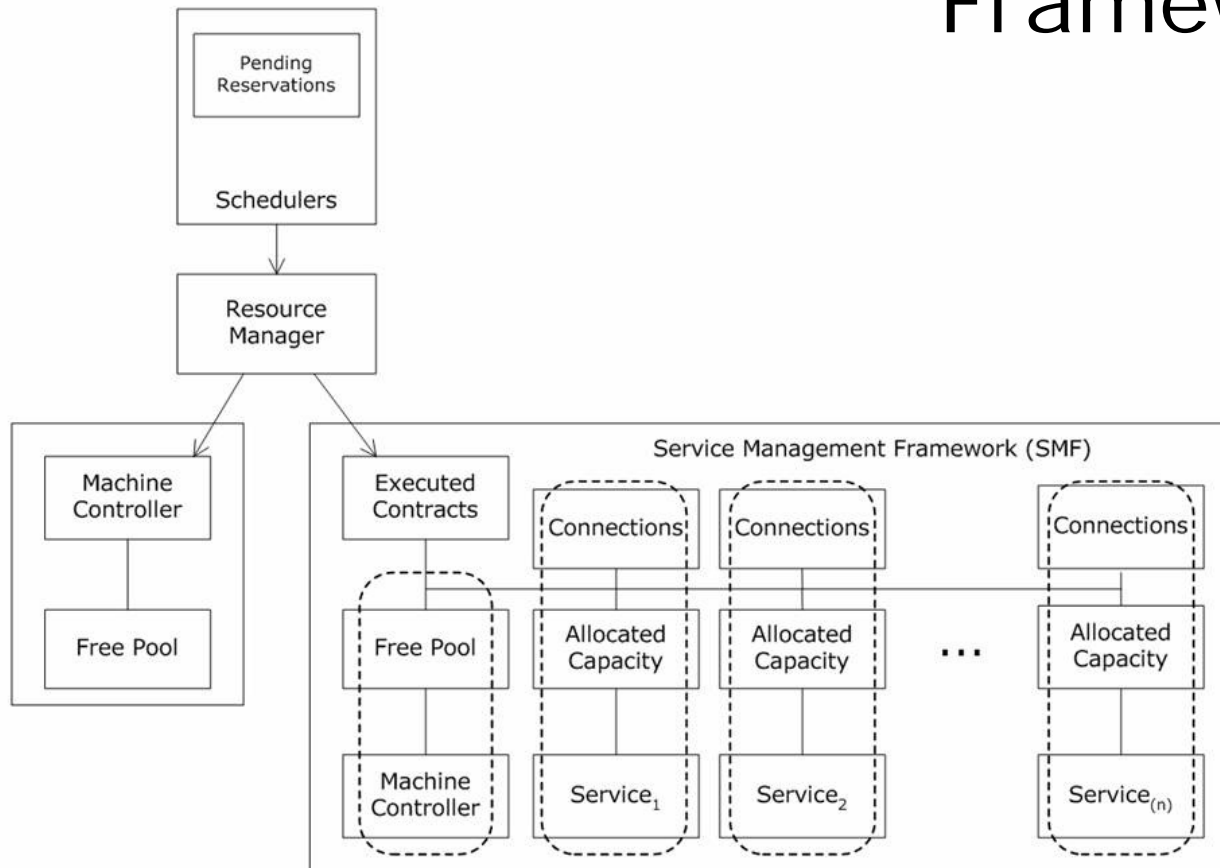

# The End